



TFP Ø 50 mm / 55 mm

Available until 31.03.2022

TFP Ø 18 mm

No longer available!



Successor: TSB

One sensor for all applications!

Successor: TSM

New, modular and better!



HYGIENIC BY DESIGN

ANDERSON-NEGELE

All advantages at [anderson-negele.com](http://anderson-negele.com)

Product Information TFP-414, -614, -814

FOOD

# Temperature Sensor with Thread G1/4" FLEXadapt



## Application/Specified usage

- Temperature measurement in weld-in thermowells and adapter

## Application examples

- For mounting in existing weld-in thermowells and adapter with cap nut G1/4"

## Features

- Sensor made of stainless steel
- Sensor tip spring-loaded at TFP-414, -414.2 and TFP-614, -614.2
- Changing or demounting without opening the process and electrical disconnecting

## Options/Accessories

- 2x Pt100 (not retrofittable)
- Programmable transmitter
- Programming adapter MPU-P 9701
- Integrated transmitter for HART-Protocol
- Integrated transmitter MPU-LCD with display in connecting head
- Pt100-chip with other classes of accuracy, (1/3 B, 1/10 B)
- Electrical connection via M12 plug (standard at TFP-614, option for TFP-414)
- Pre-assembled connecting cable for M12 plug
- Fixed cable in other lengths and other materials available

## Authorisations



## Temperature sensor TFP-414



## Temperature sensor TFP-614 with transmitter MPU-M



## Build-In systems



Suitable build-in systems for temperature sensors TFP-414, -614, -814 you will find in product information **Process Connection FLEXadapt ESF**.

Temperature sensor		
Process connection	thread G1/4" standard	weld-in thermowell / screw-in thermowell e. g. Hengesbach Quicktemp-Hülse zeh / TP136 – T500
Insertion length EL	TFP-414, TFP-414.2, TFP-614 TFP-814	61 mm, 115 mm + 2 mm spring travel 61 mm, 115 mm
Materials	connection head pipe	stainless steel 1.4301 (AISI 304) stainless steel 1.4404 (AISI 316L)
Operating pressure		acc. to manufacturer information of the thermowell
Temperature ranges	ambient sensor tip	-50...+80 °C -50...+250 °C
Measurement resistor	acc. to DIN EN 60751	Pt100
Electrical connection	TFP-414, TFP-414.2  TFP-614 TFP-814	cable gland M16x1.5 M12 plug 1.4301 (AISI 304), as option M12 plug 1.4301 (AISI 304) fixed cable (LIYY 4x 0.25 mm <sup>2</sup> ) standard 2.5 m
Protection class		IP 69 K (with electrical connection M12 plug)

Transmitter MPU-4, MPU-H, MPU-M		
Temperature ranges	ambient storage	-40...+85 °C -55...+90 °C
Measuring ranges	MPU-4, MPU-H, MPU-M	standard: -10...40 °C, 0...50 / 100 / 150 / 200 °C special ranges free programmable
Accuracy	input	< ±0.25 °C
Temperature drift	zero, span	< 0.01 % / K
Supply	MPU-4, MPU-H, MPU-M accuracy	8...35 V DC 0.01 % / V (reference: 12 V DC)
Output	signal accuracy burden	analog 4...20 mA < ±0.1 % of measurement range < 600 Ω (at U <sub>B</sub> = 24 V)
Humidity	without condensation	0...98 %

Accuracy classes of temperature sensors   Tolerances for Pt100 acc. to DIN EN 60751			
Pt100	A	1/3 B	1/10 B
0 °C / 100 Ω	±0.15 K / ±0.06 Ω	±0.10 K / ±0.04 Ω	±0.03 K / ±0.01 Ω
100 °C / 138.5 Ω	±0.35 K / ±0.13 Ω	±0.27 K / ±0.10 Ω	±0.08 K / ±0.03 Ω

Electrical connection without transmitter

With 1x M12 plug

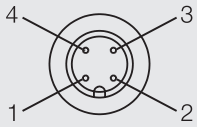

Configuration 1st M12 plug

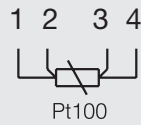

Electrical connection with transmitter

With M12 plug

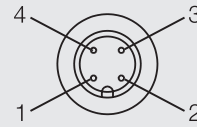

Configuration M12 plug

- 1: +supply
- 2: -supply 4...20 mA
- 3: not connected
- 4: not connected

With 1x M12 plug and 2x Pt100

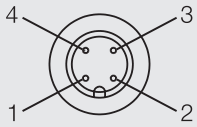

Configuration 2nd M12 plug

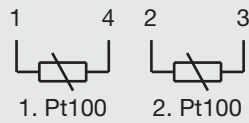

With cable gland

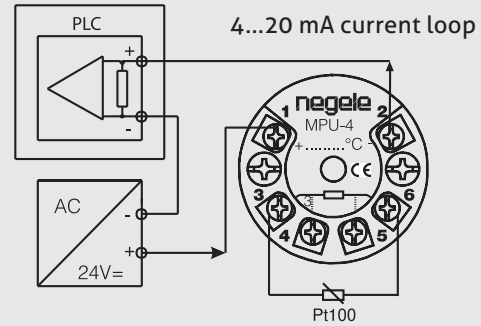

With cable gland

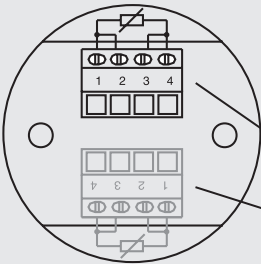

Configuration strip terminal

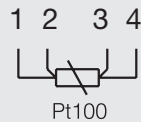

- clamps for 1st Pt100
- clamps for 2nd Pt100 (at version 2x Pt100)

With fixed cable



Fixed cable connection with 1x Pt100

wh ye bn gn standard  
rd rd wh wh PTFE

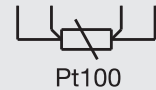

Fixed cable connection with 2x Pt100 (LIYY)

wh ye bn gn 1st Pt100  
rd bu pk gy 2nd Pt100

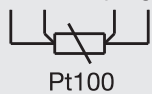

Fixed cable connection with 2x Pt100 (PTFE)

rd rd wh 1st Pt100  
vt vt ye 2nd Pt100

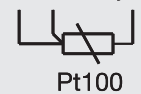

TFP-414 | TFP-414.2

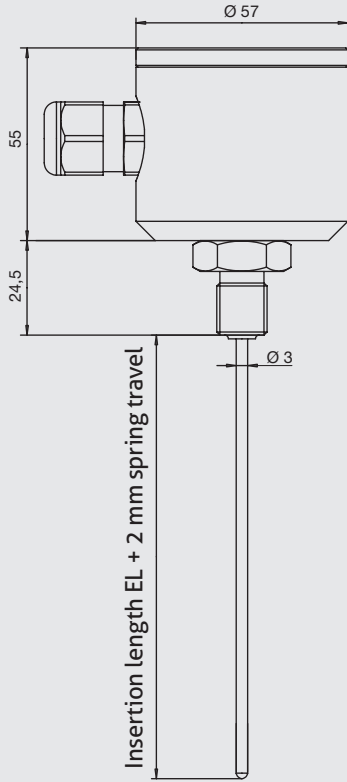

TFP-614 with MPU-M

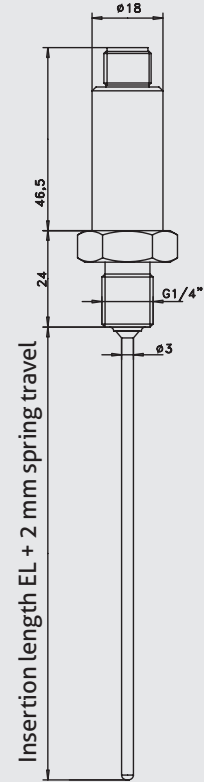

TFP-814

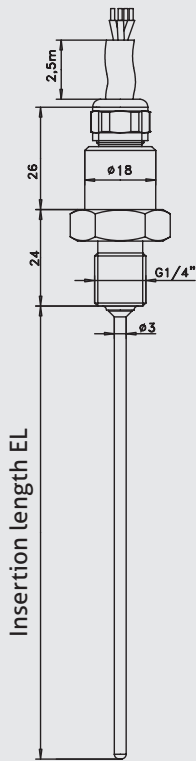

TFP-614 | TFP-624

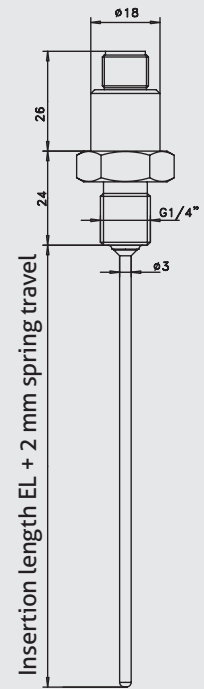

**Mechanical connection/Installation**

- Check the compatibility of the sensor to the used immersion sleeve.

**Conventional usage**

- Not suitable for applications in explosive areas.
- Not suitable for applications in security-relevant equipments (SIL).

**Transport/Storage**

- No outdoor storage
- Dry and dust free
- Not exposed to corrosive media
- Protected against solar radiation
- Avoiding mechanical shock and vibration
- Storage temperature -55 °C...+90 °C
- Relative humidity max. 98 %

**Reshipment**

- Sensors shall be clean and must not be contaminated with dangerous media!
- Use suitable transport packaging only to avoid damage of the equipment!

**Cleaning/Maintenance**

- In case of using pressure washers, don't point nozzle directly to electrical connections!

**Standards and guidelines**

- You have to comply with applicable regulations and directives.

**Disposal**

- Electrical devices should not be disposed of with household trash. They must be recycled in accordance with national laws and regulations.
- Take the device directly to a specialized recycling company and do not use municipal collection points.

**Note on CE**

- Applicable directives:  
Electromagnetic Compatibility Directive 2014/30/EU
- Compliance with the applicable EU directives is identified by the CE label on the product.
- The operating company is responsible for complying with the guidelines applicable to the entire installation.

# Temperature Transmitter MPU-LCD with Display

## Application/Specified usage

- 4...20 mA transmitter with LCD for Pt100 temperature sensor
- For installation in temperature sensor
- Sensor monitoring

## Features

- 4-digit display with green backlight
- Temperature measurement in °C and °F
- Easy range select by one button
- Lower costs for wiring because of 2-wire technology

## Note

See product information "MPU-LCD" for details.



## Option MPU-LCD (display in the connection head)



## Accessories

### PVC-cable with M12-connection made of 1.4305, IP 69 K, unshielded

M12-PVC / 4-5 m	PVC-cable 4-pin, length 5 m
M12-PVC / 4-10 m	PVC-cable 4-pin, length 10 m
M12-PVC / 4-25 m	PVC-cable 4-pin, length 25 m

### PVC-cable with M12-connection, brass nickel-plated, IP 67, shielded

M12-PVC / 4G-5 m	PVC-cable 4-pin, length 5 m
M12-PVC / 4G-10 m	PVC-cable 4-pin, length 10 m
M12-PVC / 4G-25 m	PVC-cable 4-pin, length 25 m

### Programming adapter MPU-P 9701

Programming adapter for  
MPU-4, MPU-H and MPU-M

## PVC-cable with M12-connection



## Programming adapter MPU-P 9701



## Order code for version with 1x Pt100

TFP-414 (connection head Ø 57 mm and spring-loaded sensor tip)  
 TFP-614 (connection head Ø 18 mm and spring-loaded sensor tip, electrical connection via M12 plug)  
 TFP-814 (connection head Ø 18 mm, electrical connection 2.5 m PVC-cable)

## Sensor length EL

**61** (length 61 mm)  
**115** (length 115 mm)  
**xxx** (special length)

## Diameter thermowell in mm

**3**

## Diameter sensor tip in mm

**3**

## Accuracy class Pt100

**A**  
**1/3B**  
**1/10B**

## Electrical connection (only selectable for TFP-414)

**PG** (cable gland M16x1.5)  
**M12** (M12 plug, standard with MPU-LCD)

## Transmitter only for TFP-414

**X** (without)  
**MPU-4** (programmable)  
**MPU-H** (HART-protocol)  
**MPU-LCD** (with display)

## Transmitter only for TFP-614

**X** (without)  
**MPU-M** (programmable)

## Measurement range (only for types with transmitter; not at MPU-LCD)

**-10...40** (measurement range -10...+40 °C)  
**0...50** (measurement range 0...+50 °C)  
**0...100** (measurement range 0...+100 °C)  
**0...150** (measurement range 0...+150 °C)  
**0...200** (measurement range 0...+200 °C)  
**xx...yy** (special range)



**TFP Ø 50 mm / 55 mm**  
 Available until 31.03.2022

**TFP Ø 18 mm**  
 No longer available!



**Successor: TSB**  
 One sensor for all applications!

**Successor: TSM**  
 New, modular and better!

All advantages at [anderson-negele.com](http://anderson-negele.com)

TFP-414 /

115 /

3 /

3 /

A /

M12 /

MPU-4 /

0...150

## Order code for version with 2x Pt100

<b>TFP-414.2</b>	(connection head Ø 57 mm and spring-loaded sensor tip, no transmitter possible!)				
<b>TFP-614.2</b>	(connection head Ø 18 mm and spring-loaded sensor tip, electrical connection via M12 plug, no transmitter possible!)				
	<b>Sensor length EL</b>				
	<b>61</b>	(length 61 mm)			
	<b>115</b>	(length 115 mm)			
	<b>xxx</b>	(special length)			
		<b>Diameter thermowell in mm</b>			
		<b>3</b>			
			<b>Diameter sensor tip in mm</b>		
			<b>3</b>		
				<b>Accuracy class Pt100</b>	
				<b>A</b>	
				<b>1/3B</b>	
				<b>1/10B</b>	
				<b>Electrical connection (only selectable for TFP-414.2)</b>	
				<b>PG</b> (cable gland M16x1.5)	
				<b>M12</b> (M12 plug)	
<b>TFP-414.2 /</b>	<b>115 /</b>	<b>3 /</b>	<b>3 /</b>	<b>A /</b>	<b>M12</b>



**TFP Ø 50 mm / 55 mm**  
Available until 31.03.2022

**TFP Ø 18 mm**  
No longer available!



**Successor: TSB**  
One sensor for all applications!

**Successor: TSM**  
New, modular and better!

All advantages at [anderson-negele.com](http://anderson-negele.com)