

Product Information NVS-50, -110, -120, -345

FOOD

Conductive Multilevel Sensor



Application/intended use

- Point level measurement in aqueous, conductive media in tanks and pipes with minimum conductivity. The conductivity depends on the evaluation device: 1 µS/cm when using external evaluation units, e.g. VNV / ZNV series and 10 µS/cm when using the internal level transmitter MNV-1C.

Application examples

- Empty/full indication in tanks
- Level control in tanks
- Overfill protection in dosing systems

Hygienic design/process connection (NVS-345 and NVS-50 only)

- Hygienic and easy-to-sterilize measuring point
- Elastomer-free sealing system for gap-free sensor installation without dead space
- CIP/SIP cleaning up to 143 °C (289 °F) / 120 min
- Sensor made entirely of stainless steel and PEEK; PFA coating
- Adapters for all standard process connections
- Product-contacting parts are compliant with EU Regulation 10/2011 and FDA (NVS-345 and NVS-50)

Special features/advantages

- Defined position of the cable entry (NVS-345 only)
- Available with or without an integrated level transmitter MNV-1C
- Choice of different electrical connections
- Electrodes can be shortened and bent as required

NVS-345/...B

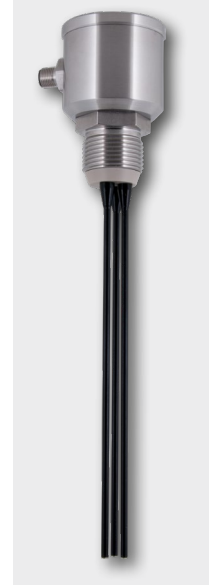

NVS-50/...N



NVS-110/...B



Accessories

Instead of the integrated level transmitter, standard multi-level sensors can also be used with external devices for installation on DIN rails, for example.

The full selection of external evaluation units, the technical data and the order code can be found in the „Evaluation units for conductive multilevel sensors“ product information.

Overview of the evaluation units for DIN-rail installation ZNV-2, VNV-2



Technical data				
Type	NVS-50	NVS-345	NVS-110	NVS-120
Process connection	Milk pipe DIN11851 DN50; hygienic	Thread G1"; hygienic	Thread G1" standard; not hygienic	Thread G1½" standard; not hygienic
Electrodes				
Quantity	Max. 5	Max. 4	Max. 4	Max. 5
Length [mm]	200; 500; 850; 1000; 1500; 2000	200; 500; 850; 1000; 1500; 2000	200; 500; 850; 1000; 1500; 2000	200; 500; 850; 1000; 1500; 2000
Diameter	4 mm (8 mm optional)	4 mm (8 mm optional)	4 mm (8 mm optional)	4 mm (8 mm optional)
Temperature ranges*				
Ambient	-10...60 °C / 14...140 °F	-10...60 °C / 14...140 °F	-10...60 °C / 14...140 °F	-10...60 °C / 14...140 °F
Process	0...110 °C / 32...230 °F	0...110 °C / 32...230 °F	0...90 °C / 32...194 °F	0...90 °C / 32...194 °F
CIP/SIP cleaning	143 °C (289 °F) / 120 min.	143 °C (289 °F) / 120 min.		
Process pressure	Max. 10 bar / 145 psi	Max. 10 bar / 145 psi	Max. 10 bar / 145 psi	Max. 10 bar / 145 psi
Tightening torque	-	10...20Nm	-	-
Materials				
Connecting head	Stainless steel 1.4301 / AISI 304	Stainless steel 1.4301 / AISI 304	PP hard plastic	PP hard plastic
(Threaded) connector	Stainless steel 1.4301 / AISI 304	Stainless steel 1.4301 / AISI 304	PP hard plastic	PP hard plastic
Electrodes	Stainless steel 1.4404 / AISI 316L	Stainless steel 1.4404 / AISI 316L	Stainless steel 1.4404 / AISI 316L	Stainless steel 1.4404 / AISI 316L
Insulator	PEEK	PEEK	-	-
Coating (electrodes)	PFA	PFA	PFA	PFA
Electrical connection	M12 plug connection (1.4301 / AISI 304), not for NVS-50 with 5 electrodes Cable gland M16 x 1.5			
Protection class	IP69 K (with M12 plug connection) IP67 (with cable gland)			

*) When using the integrated level transmitter MNV-1C, please note the temperatures specified below in the technical data of the level transmitter.

Technical data of level transmitter MNV-1C		
Temperature	Operation	-10...60 °C / 14...140 °F
	Storage	-20...60 °C / -4...140 °F
Humidity	Without condensation	0...95 % r. F.
Supply voltage		15...36 V DC
Electrode E	Voltage	1.5...2 V AC/300 Hz, no DC signal
Adjustable sensitivity	MNV-1C	0.1; 1; 10; 100 kΩ
Output	Short-circuit-proof	Active 50 mA
Delay	Fixed	0.5 s
Switching function	Selectable min./max.	MNV-1C jumper

Selection of the right sensor type



Coating:

For foamy, adhesive (e.g. yogurt) and/or wetting media (e.g. alkaline solutions), we suggest using a sensor with a coated electrode. Sensors with an uncoated electrode are recommended for aqueous, non-adhesive and non-wetting media. If rod lengths are greater than 500 mm, the coated version should be used since the electrodes may come into contact with each other and lead to incorrect readings.

Explanation of switching states

Full indicator: The output is active when immersed
Empty indicator: The output is active when not immersed

Level transmitter MNV-1C

- 1: LED sensor (lights up when the sensor is immersed in the medium, regardless of the switching function)
- 2: Terminal block
- 3: Empty/full jumper
- 4: Sensitivity jumper

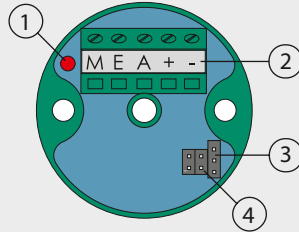

Configuration of level transmitter MNV-1C

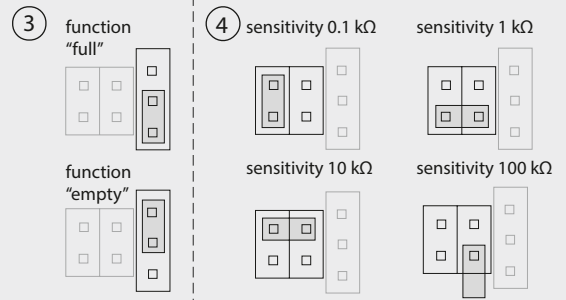

Standard setting on delivery
 3: full
 4: 10 kΩ

Setting up level transmitter MNV-1C



- Connect the supply voltage.
- Set the switching function. See the adjacent configuration description.
- Set the lowest sensitivity. See the adjacent configuration description.
- Wet the sensor with the least conductive medium.
- If the output switches, the selected sensitivity can be retained and the calibration is finished. If the output does not switch, please continue as follows:
- Increase the sensitivity until the output switches. Once this happens, calibration is finished.

Electrical connection

With MNV-1C

Terminal block

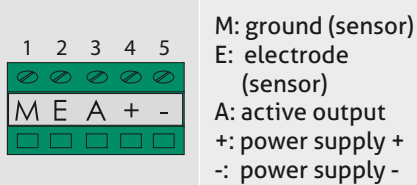

M12 connector

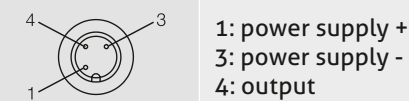

NVS-50 up to 4 electrodes

Terminal block

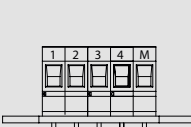

View from top

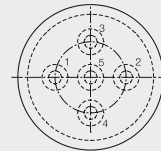

M12 connector

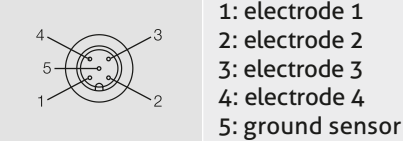

NVS-50 with 5 electrodes

Terminal block



View from top

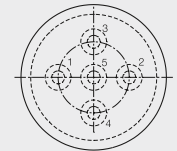

M12 connector not possible

NVS-110, NVS-120

Terminal block

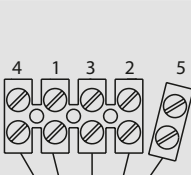

View from top

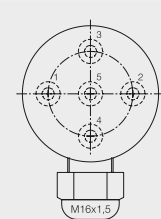

M12 connector

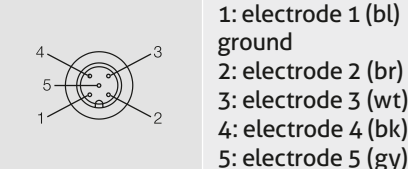

NVS-345

Terminal block

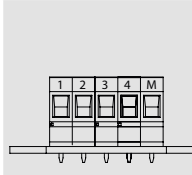

View from top

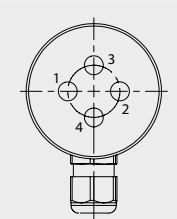

M12 connector

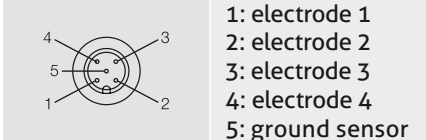



General setup procedure

- If necessary, cut the electrodes to the required lengths. In doing so, ensure that the compound between the rod and the thread connector is not strained excessively. If using coated electrodes, do not damage the insulation of the rod part that remains on the sensor.
- Strip 5 mm of insulation off the tip of insulated rods.
- Screw the sensor into the sleeve and connect as shown in the wiring diagram. Do not damage the coating when inserting the sensor into the sleeve.

NVS-345

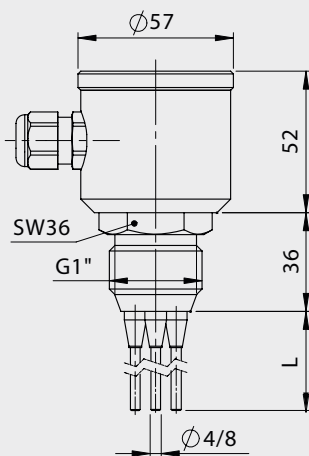

NVS-50

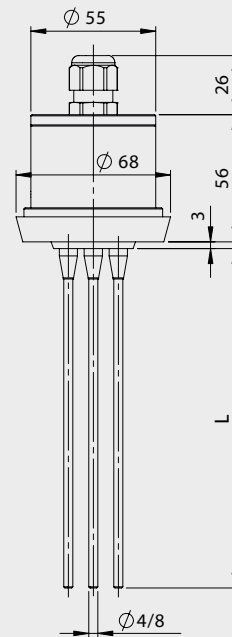

NVS-110

This sensor does not conform to hygienic requirements.

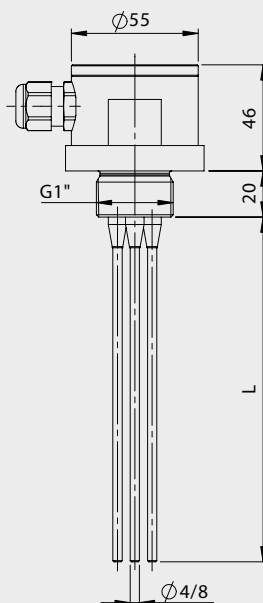

NVS-120

This sensor does not conform to hygienic requirements.

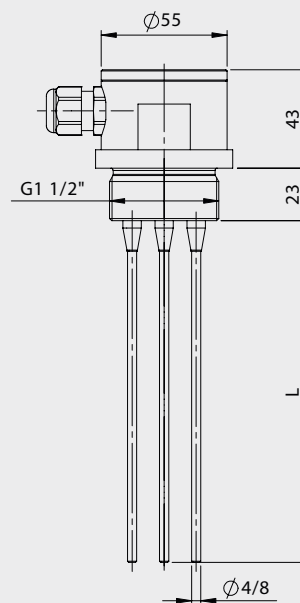

Note on material conformity as per European Regulation 1935/2004 or 10/2011

- The plastics used in the NVS-345 and NVS-50 sensors are materials approved by European Regulations 1935/2004 and 10/2011 for contact with food.
- The materials of the NVS-110 and NVS-120 sensors are not in accordance with the European regulations specified above.

Mounting instructions

- When installing the NVS-345, only use Negele weld-in systems to ensure proper functioning of the measuring point.
- When screwing in the sensors, do not exceed the maximum permissible torque (see the technical data on page 2).
- If the tank wall is being used as the reference electrode (only possible with NVS-345 and NVS-50), ensure that the sensor process connection makes good electrical contact with the pipe and tank wall. Do not use insulating sealants such as Teflon. The tank wall must be made of metal in this case.
- When installing the sensors, ensure that the electrode emerges from the medium when it is drained.
- When tightening and loosening the sensor, only use the wrench flats provided this purpose, never the connecting head.

Cleaning/Maintenance

- When using a pressure washer, do not point the nozzle directly at the electrical connections.

Reshipment

- Sensors and process connection must be clean and must not be contaminated with hazardous media and/or heat-conductive paste. Note the cleaning information!
- To avoid damage of the equipment, use suitable transport packaging only.

Note on CE

- Applicable directives: Electromagnetic Compatibility Directive 2014/30/EU
- Compliance with the applicable EU directives is identified by the CE label on the product.
- The operating company is responsible for complying with the guidelines applicable to the entire installation.

Transport/Storage

- No outdoor storage
- Store in an area that is dry and dust-free
- Do not expose to corrosive media
- Protect against solar radiation
- Avoid mechanical shock and vibration
- Storage temperature 0...40 °C / 32...104 °F
- Relative humidity max. 80 %

Standards and guidelines

- Compliance with the applicable regulations and directives is mandatory.

Disposal

- Electrical devices should not be disposed of with household trash. They must be recycled in accordance with national laws and regulations.
- Take the device directly to a specialized recycling company and do not use municipal collection points.

Order code for standard multilevel sensors

NVS	Head diameter 55mm of stainless steel with CLEANadapt G1" hygienic process connection								
-345	Head diameter 55mm of plastic with G1" process connection								
-110	Head diameter 55mm of plastic with G1½" process connection								
-120	Head diameter 55mm of stainless steel with dairy flange DN50 as per DIN11851								
-50									
	Electrode 1								
	200N	uncoated 200 mm, diameter 4 mm							
	200N-8	uncoated 200 mm, diameter 8 mm							
	200B	coated 200 mm, diameter 4 mm							
	200B-8	coated 200 mm, diameter 8 mm							
	500N	uncoated 500 mm, diameter 4 mm							
	500N-8	uncoated 500 mm, diameter 8 mm							
	500B	coated 500 mm, diameter 4 mm							
	500B-8	coated 500 mm, diameter 8 mm							
	850N	uncoated 850 mm, diameter 4 mm							
	850N-8	uncoated 850 mm, diameter 8 mm							
	850B	coated 850 mm, diameter 4 mm							
	850B-8	coated 850 mm, diameter 8 mm							
	1000N	uncoated 1000 mm, diameter 4 mm							
	1000N-8	uncoated 1000 mm, diameter 8 mm							
	1000B	coated 1000 mm, diameter 4 mm							
	1000B-8	coated 1000 mm, diameter 8 mm							
	1500N	uncoated 1500 mm, diameter 4 mm							
	1500B	coated 1500 mm, diameter 4 mm							
	2000N	uncoated 2000 mm, diameter 4 mm							
	2000B	coated 2000 mm, diameter 4 mm							
	2500N	uncoated 2500 mm, diameter 4 mm							
	[mm]N	Special length, uncoated							
	[mm]B	Special length, coated							
		Electrode 2							
		selection options: see Electrode 1							
		Electrode 3							
		selection options: see Electrode 1, evaluation unit not possible							
		Electrode 4							
		selection options: see Electrode 1, evaluation unit not possible							
		Electrode 5							
		not for NVS-345, selection options: see Electrode 1, evaluation unit not possible							
		Evaluation unit / level transmitter							
		X	without						
		M	integrated in head; only for 2 electrodes						
		Open circuit monitoring							
		only possible with external evaluation unit							
		X	without						
		D	with open circuit resistance, only possible with 2 electrodes						
		Electrical connection							
		X	cable gland M16x1.5						
		M12	M12 connector, not for NVS-50 with 5 electrodes						
	NVS- 345	200B/	500B /	850B /	850B /	X /	X /	X /	M12