

Level Sensor with G1/2" Thread Hygienic



Application/intended use

- Limit detection of aqueous and conductive media in vessels and pipes with minimum conductivity. The conductivity depends on the evaluation device: 1 μ S/cm when using external evaluation units, e.g. VNV / ZNV series, and 10 μ S/cm when using the internal evaluation unit MNV-1C or MNV-M.

Application examples

- Limit detection of fluids in vessels (where the sensor is built in from the side) or pipes
- Full alarm in vessels and tanks where the sensor is built in from the top
- Empty alarm in vessels and tanks where the sensor is built in from the bottom
- Product monitoring in pipes
- Pump/dry-running protection
- Level control in tanks
- Overfill protection in dosing systems

Hygienic design/process connection

- Hygienic process connection with CLEANadapt
- Versions available with EHEDG approval
- Versions compliant to 3-A Standard 74- available
- All wetted materials are FDA-conform
- Sensor completely made of stainless steel and PEEK, coating made of PFA
- Complete overview of process connections: see product information CLEANadapt
- The Anderson-Negele CLEANadapt system offers a flow-optimized, hygienic and easily sterilizable installation solution for sensors.

Special features/advantages

- CIP/SIP cleaning up to 143 °C (289 °F)/120 minutes max.
- Defined position of the cable entry
- Available with or without an integrated level transmitter
- Different electrical connections available
- Rods may be shortened and twisted as needed
- Miniature edition, installation in pipes beginning at DN25 possible
- Fully molded to avoid condensation

Options/accessories

- High-temperature version available (with 100-mm spacer; for use in processes with constant temperatures of up to 140 °C (284 °F))
- Fixed cable also available in other cable lengths

Selection of the right sensor type

- **Coating**
For foamy, adhesive (e.g. yoghurt) and/or wetting media (e.g. alkaline solutions), we suggest using a sensor with a coated rod. Sensors with uncoated rods are only suitable for aqueous, non-adhesive and non-wetting media.
- **Temperature**
If a sensor with an integrated level transmitter MNV is needed, we suggest using the high-temperature version with a spacer (option H) if the medium temperature exceeds 60 °C (140 °F).

Communication

 0/1

NVS-143



NVS-141



NVS-161



Specification of level sensor		
Process connection	crevice-free torque thread size	CLEANadapt build-in system, e.g. EMK-132 or EHG-.../1/2" 5...10 Nm G1/2"
Material	connecting head rod insulating part coating	1.4301 (AISI 304) 1.4404 (AISI 316L) PEEK (FDA approval number 21CFR177.2415) PFA (FDA approval number 21CFR177.2440, 21CFR177.1550)
Surface quality		$R_a \leq 0.8 \mu\text{m}$ (wetted parts)
Weight		approx. 500 g
Rods	NVS-141; -161; -181 NVS-143; -146; -163; -166; -183; -186	\varnothing 4 mm, length: 200; 500; 850; 1000; 1500; 2000 mm (may be shortened to the requested length) \varnothing 8 mm, length: 18 mm
Operating pressure		max. 10 bar
Temperature ranges*	process NVS-14x process NVS-16x, NVS-18x CIP/SIP ambient	0...140 °C (32...284 °F) 0...100 °C (32...212 °F) 143 °C (289 °F)/120 minutes -10...60 °C (14...140 °F)
Electrical connection	cable gland plug connection fixed cable 2.5 m - with level transmitter - without level transmitter	M16x1.5 (PG) M12 plug, 1.4301 (AISI 304) PVC 4x 0.25 mm ² silicone 2x 0.5 mm ²
Protection class	with M12 plug connection with cable connection	IP 69 K IP 67

*) When the MNV level module is integrated, please note the temperatures specified below in the technical data of the level transmitter.

Specification of MNV level transmitter (attention: differs from the basic unit)		
Temperature ranges	operation storage	-10...60 °C (14...140 °F) (with NVS standard equipment) -10...140 °C (14...284 °F) (with NVS high-temp. version) -20...60 °C (-4...140 °F)
Humidity	without condensation	0...95% r. H.
Power supply		18...36 V DC
Electrode E1	measuring voltage	1.5...2 VAC/300 Hz no DC signal
Selectable sensitivity	MNV-1C MNV-M	0.1 k Ω ; 1 k Ω ; 10 k Ω ; 100 k Ω (via jumper) 0.2 k Ω ; 2 k Ω ; 20 k Ω (via control input voltage (Tri-State-Logic))
Output		PNP (active 50 mA, short-circuit-proof)
Delay	fixed	0.5 s
Switching function min/max selectable	MNV-1C MNV-M	via jumpers polarization of power supply

NVS-141/M

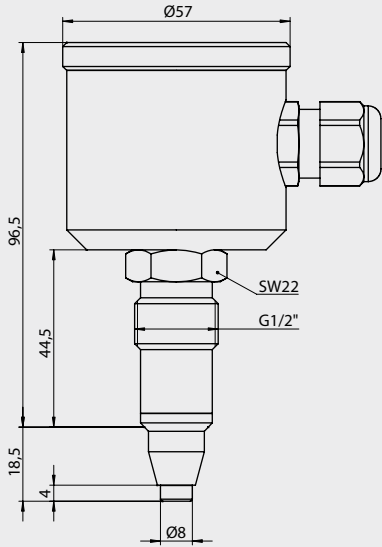

NVS-143/... | NVS-146/...

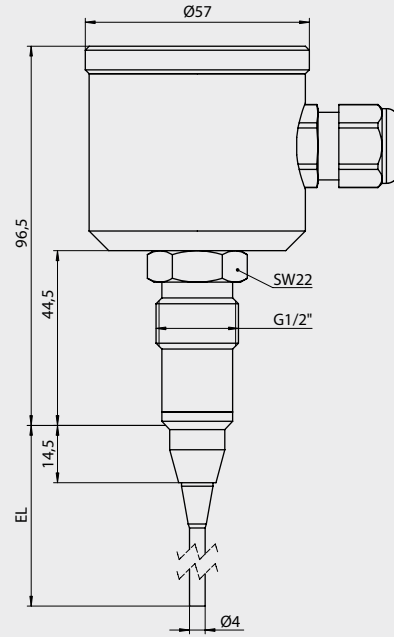

NVS-143/.../H | NVS-146/.../H

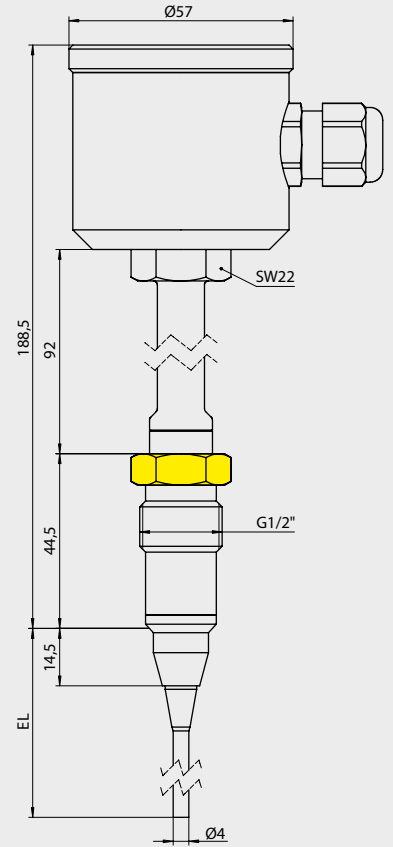

Advice for NVS-143/.../H



Tighten the sensor only at the lower, marked in yellow spanner flat (BE = 22 mm)!

NVS-163 | NVS-166

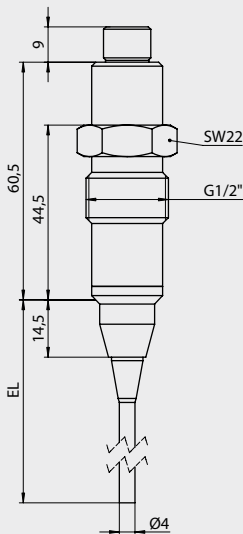

NVS-163/M | NVS-166/M

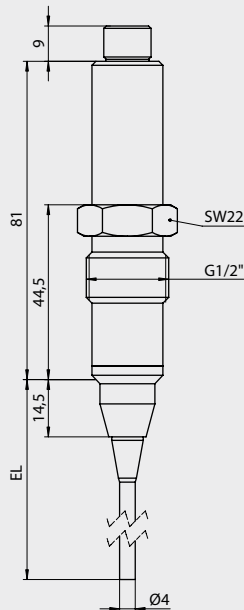

NVS-181

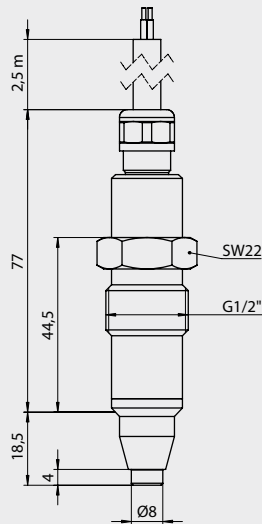

NVS-183/M

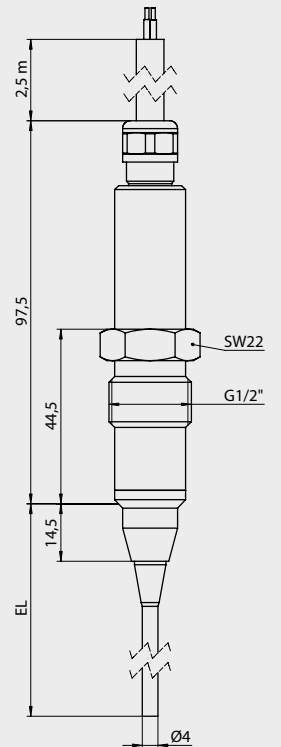

Electrical connection without level transmitter

With terminals

EO	rod (sensor)	
M	GND	

Electrical connection with MNV-1C, MNV-M transmitter

With clamps (with level transmitter MNV-1C)

M	GND	
E	rod (sensor)	
A	active output	
+	+power supply	
-	-power supply	

With M12 plug

Configuration of the M12 plug

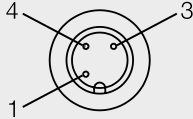
1 (brown)	not connected	
2		
3 (blue)	GND	
4 (black)	sensor	

With M12 plug (with level transmitter MNV-M)

Configuration of the M12 plug (full alarm)

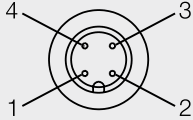
1 (brown)	+power supply	
2 (white)	control input sensitivity	
3 (blue)	-power supply	
4 (black)	active output	

With fixed cable

With PVC/silicone cable

brown	rod	
blue	GND	
With Teflon cable (PTFE)		
red	rod	
white	GND	

With fixed cable (with level transmitter MNV-M)

With PVC cable (full alarm)

white	+power supply	
yellow	control input sensitivity	
brown	-power supply	
green	active output	
Notice: silicone and/or Teflon cables (PTFE) are not available in this version.		

Instructions on the electrical connection with level transmitters MNV-1C, MNV-M



The sensitivity and the switching behavior of sensors with level transmitters may be configured using an electrical connection or a jumper. Please also take note of the figures on the next page.

Setting up the MNV-1C, MNV-M level transmitters



- Connect the supply voltage.
- Select the switching function (see "Configuration of the level transmitter").
- Select the minimum sensitivity (see "Configuration of the level transmitter").
- Wet the sensor with the least conductive medium.
- If the output switches, the selected sensitivity may be retained and calibration is finished. If the output does not switch, please continue as follows.
- Increase the sensitivity until the output switches. Once this happens, calibration is finished.

Switching state explanation

Full indicator: The output is active when immersed
Empty indicator: The output is active when not immersed

Level transmitter MNV-1C

- 1: LED sensor (lights up when the sensor is immersed, independent of the switching function)
- 2: Terminal block
- 3: Full/empty jumper
- 4: Sensitivity jumper

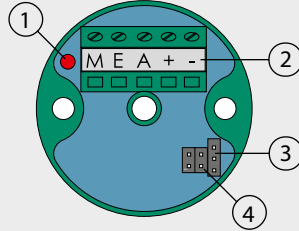

Configuration of the MNV-1C level transmitter

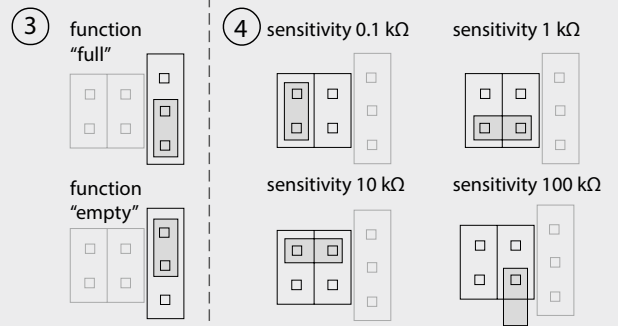

Standard setting on delivery
 3: full
 4: 10 kΩ

Configuration of the MNV-M level transmitter with NVS-161/M; NVS-163/M; NVS-166/M

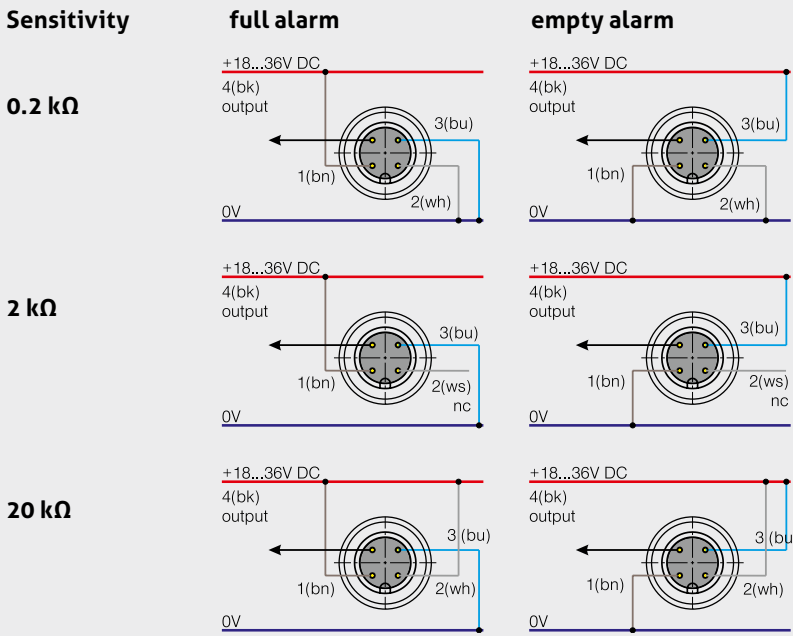

Configuration of the MNV level transmitter with NVS-181/M; NVS-183/M; NVS-186/M

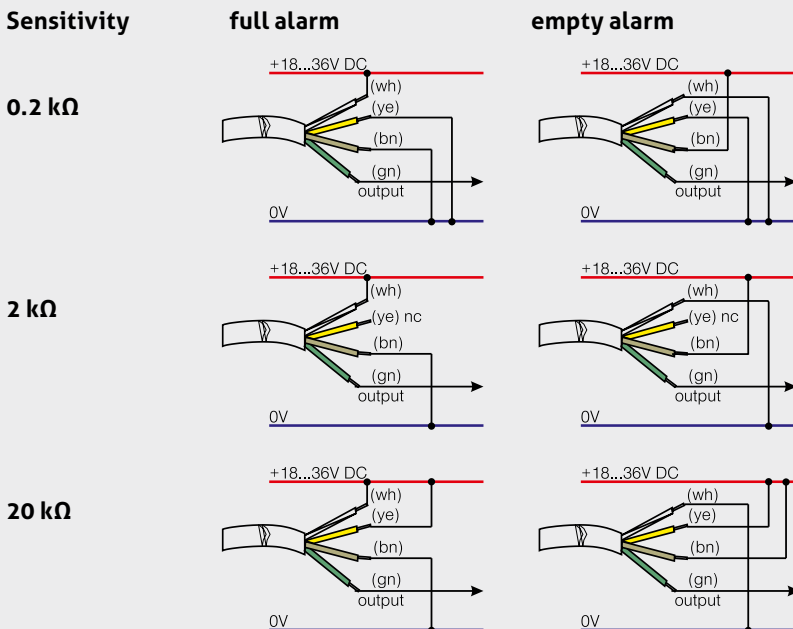



General installation

- If necessary, cut the rods to the required lengths. In doing so, ensure that the compound between the rod and the thread connector is not strained excessively. If using coated rods, do not damage the insulation of the rod part that remains on the sensor.
- Strip 5 mm of insulation off the tip of coated rods (the length depends on the conductivity of the medium).
- Screw the sensor into the sleeve and connect as shown in the wiring diagrams. Do not damage the coating when you mount the sensor in the sleeve.



Mounting instructions

- Do not exceed the maximum torque when you screw in the sensor.
- To guarantee reliable operation of the measuring point, make sure you have a good electrical connection between the process connection thread of the sensor and the pipe or vessel wall.
- Do not use any kind of sealing tape, such as Teflon tape. Also follow the instructions in the CLEANadapt product information if necessary.
- If the stub sensor is used in pipes, ensure that the rod emerges from the liquid when the medium is drained. We suggest installing the sensor in vertical pipes.
- Tank and pipe walls must be made of metal.
- For mounting and removing the sensor, please use the wrench flats only. Do not use the connecting head.

Note on 3-A Sanitary Standard 74-



Information on installation according to 3-A standard is available on our website:
www.anderson-negele.com/3A74.pdf

Click on the PDF icon to download the document.

Note on EHEDG Hygienic Standard Type EL Class I



Information on installation according to EHEDG standard is available on our website:
www.anderson-negele.com/EHEDG.pdf

Click on the PDF icon to download the document.



Information on CLEANadapt process connections

Please find the complete overview of all adapters available as well as the respective technical data in the product information on CLEANadapt process adapters.

Selection of possible process connections

					
Process connection	Build-in system EHG (DIN 11865 series 2)	Weld-in sleeve	Weld-in ball	Collar sleeve	

Cleaning/Maintenance

- When using a pressure washer, do not point the nozzle directly at the electrical connections.

Reshipment

- Sensors and process connection must be clean and must not be contaminated with hazardous media and/or heat-conductive paste. Note the cleaning information!
- To avoid damage of the equipment, use suitable transport packaging only.

Note on CE

- Applicable directives:
Electromagnetic Compatibility Directive 2014/30/EU
- Compliance with the applicable EU directives is identified by the CE label on the product.
- The operating company is responsible for complying with the guidelines applicable to the entire installation.

Transport/Storage

- No outdoor storage
- Store in an area that is dry and dust-free
- Do not expose to corrosive media
- Protect against solar radiation
- Avoid mechanical shock and vibration
- Storage temperature -20...60 °C (-4...140 °F)
- Relative humidity max. 80%

Standards and guidelines

- Compliance with the applicable regulations and directives is mandatory.

Disposal

- Electrical devices should not be disposed of with household trash. They must be recycled in accordance with national laws and regulations.
- Take the device directly to a specialized recycling company and do not use municipal collection points.

Information on external evaluation devices

Please find the complete overview of all external evaluation devices available as well as the respective technical data in the product information on evaluation electronics for conductive limit switches VGW-2 and VNV-2/ZNV-2.

Order code

NVS-14 connecting head ø 55 mm with cable gland M16x1.5
NVS-16 connecting head ø 18 mm with M12 plug
NVS-18 connecting head ø 18 mm with fixed cable 2.5 m; other cable lengths: on request

Rod (Ⓐ: 3-A compliant, Ⓔ: EHEDG approval)

1/00 uncoated, stub sensor EL = 4 mm (Ⓐ) (Ⓔ)
3/200 uncoated 200 mm, ø 4 mm (Ⓐ) (Ⓔ)
3/200-8 uncoated 200 mm, ø 8 mm (Ⓐ) (Ⓔ)
6/200 coated 200 mm, ø 4 mm
6/200-8 coated 200 mm, ø 8 mm
3/500 uncoated 500 mm, ø 4 mm (Ⓐ) (Ⓔ)
3/500-8 uncoated 500 mm, ø 8 mm (Ⓐ) (Ⓔ)
6/500 coated 500 mm, ø 4 mm
6/500-8 coated 500 mm, ø 8 mm
3/850 uncoated 850 mm, ø 4 mm (Ⓐ) (Ⓔ)
3/850-8 uncoated 850 mm, ø 8 mm (Ⓐ) (Ⓔ)
6/850 coated 850 mm, ø 4 mm
6/850-8 coated 850 mm, ø 8 mm
3/1000 uncoated 1000 mm, ø 4 mm (Ⓐ) (Ⓔ)
3/1000-8 uncoated 1000 mm, ø 8 mm (Ⓐ) (Ⓔ)
6/1000 coated 1000 mm, ø 4 mm
6/1000-8 coated 1000 mm, ø 8 mm
3/1500 uncoated 1500 mm, ø 4 mm (Ⓐ) (Ⓔ)
3/1500-8 uncoated 1500 mm, ø 8 mm (Ⓐ) (Ⓔ)
6/1500 coated 1500 mm, ø 4 mm
6/1500-8 coated 1500 mm, ø 8 mm
3/2000 uncoated 2000 mm, ø 4 mm (Ⓐ) (Ⓔ)
3/2000-8 uncoated 2000 mm, ø 8 mm (Ⓐ) (Ⓔ)
6/2000 coated 2000 mm, ø 4 mm
6/2000-8 coated 2000 mm, ø 8 mm
3/[mm] special length uncoated (length in mm) (Ⓐ) (Ⓔ)
6/[mm] special length coated (length in mm)

Evaluation unit

X without
M integrated in connecting head; type-specific with MNV-1C or MNV-M

High-temperature version

X standard, only for sensors without evaluation unit and type-specific process temperatures (see technical data)
H with spacer: recommended for **evaluation unit** and process temperatures > 60 °C (140 °F)
ATTENTION: Please note the specifications regarding process temperature as given in the technical data.

Wire-break monitoring

(only possible with an external evaluation unit VNV-SD or VNV-W)

X without
D with wire-break resistor

Electrical connection (not selectable at NVS-16x and NVS-18x)

X cable gland M16x1.5
M12 M12 plug

NVS-14 **3/200 /** **M /** **H /** **X /** **M12**