

Universal Transmitter

Application Example

- Temperature transmitting into standardised electrical signals
- Flow measurement
- Rotation speed measurement
- Isolation of electrical signals

Special Features

- Compact design, only 22,5mm wide
- Dual-line LC display with additional display elements
- Convenient 3-key operation
- Direct communication between mounted transmitters, fieldbus connections via bus coupler
- Up to two universal inputs for TC, RTD, R, I, U, f
- Universal output with combined current / voltage output
- Combined counter or frequency input resp. output
- Up to two relay outputs
- Customized linearization
- Min-, Max-indicator
- Galvanic isolation between input and output as well as power supply
- Fast response (100ms cycle time)
- Sensor monitoring
- Build in transmitter power supply

Options / Accessories

- Second universal input
- Connector set with screw terminals
- Additional relay output
- Counter input
- Frequency input and output
- RS 485 / Modbus protocol
- Fieldbus coupler PROFIBUS DP
- System interface (only for 24V version)
- Engineering-Tool BlueControl® for configuration, parameter setting and operation
- Power supply module

Functions

- Standard (actual value X1)

As Option:

- Difference (X1-X2)
- Maximum / Minimum value
- Average of X1 and X2
- Switchover between X1 and X2
- Counter, frequency measuring
- Actual value of INP1, temperature compensation with INP2

Signal processing

- Measurement value correction (offset and 2-point)
- Scaling
- 1st-order filter
- Linearization with 31 segments
- Radical function
- Integrator

Behavior on sensor break / short circuit

- Response of the analog output is selectable (upscale / downscale)
- Preset substitute input value, can be disabled



NCI-45-rail

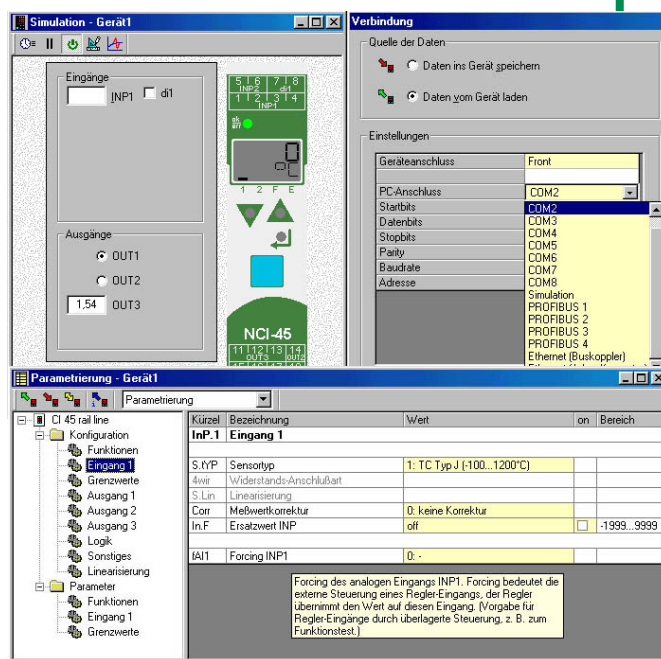

BlueControl-Software

Specification NCI-45

General

Display	LCD	dual-line + display elements
Power supply	(acc. to order)	
	alternating current	90...260VAC / 48...62Hz
	or universal supply	18...30VAC / 48...62Hz
		18...31VDC
Protection class	housing	IP20
Perm. temperatures	operation	-10...55°C
	temperature drift	≤ 0,05% / 10K
	storage	-30...70°C
Humidity		95% max., no condensation

Inputs

INP1+INP2	thermocouple inputs	type L, J, K, N, S, R, T, C, D, E, B
	resistive inputs	Pt100, Pt1000, KTY 11-6 (3-wire)
	potentiometric	0...4,5kOhm (3-wire)
	current	0...20mA
	voltage	0...10V, -10...10V, -5...5V, -500...500mV
INP2	digital input DI1	potential-free contact input
	counter input (option)	pulse counter for up or down counting, no storing
	optocoupler (option)	for active control signals
	frequency (option)	input with optocoupler
		0...100kHz

Outputs

OUT1+OUT2	relays, 2 no-contacts	500VA, 250V, 2A max.
OUT3	0/4-20mA, 0-10V	short circuit proof burden 700Ohm
	0-10V	not continuous short circuit proof burden ≥ 2kOhm
	0,025...1kHz pulse output	square wave 0...5Hz, 5Imp/s max. pulse duration 100/140ms
	transmitter supply	22mA / ≥ 13V
Accuracy		≤ 0,1%
Resolution		≤ 1,5µA bzw. 0,75mV

Operation Elements: see Operation Manual

Electrical Connection NCI-45

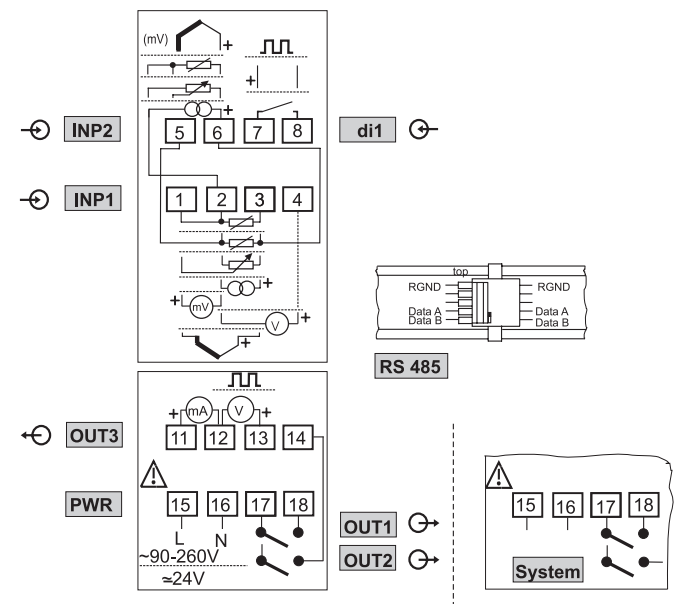

Drawing NCI-45

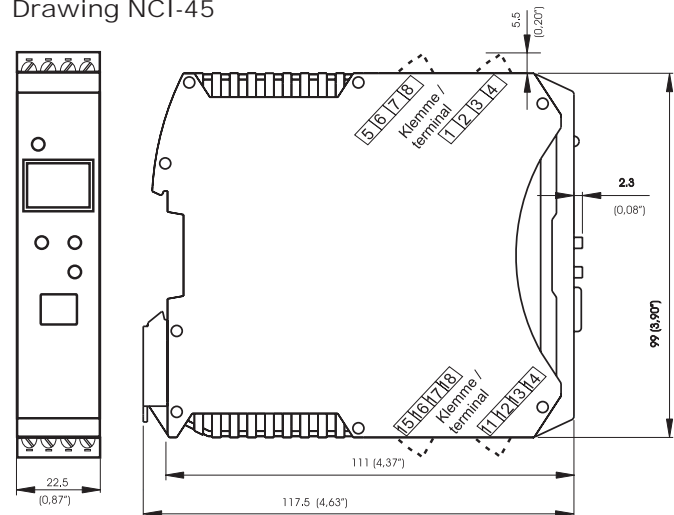

Table Functionality of BlueControl®-Versions

Functionality	Basic	Expert
parameter and configuration setting	yes	yes
controller and loop simulation	yes	yes
download: transfer of an engineering to the controller	yes	yes
online mode / visualisation	yes	yes
defining an application specific linearization	yes	yes
configuration in the extended operating level	yes	yes
upload: reading an engineering from the controller	yes	yes
basic diagnostic functions	no	yes
saving data file and engineering	yes	yes
printer function	yes	yes
online documentation, help	yes	yes
implementation of measurement value correction	yes	yes
data acquisition and trend display	yes	yes
wizard function	yes	yes
extended simulation	no	yes
customer-specific default data-set	no	yes
programeditor (NKS-90-1 programmer only)	no	yes
Rail line system support	no	yes

General

BlueControl® is a powerful tool for setting parameters, simulation, commissioning and diagnosing BluePort®-devices.

Description

The primary function of BlueControl® is parametrizing of control equipment with the assistance of plain texts, a clear structure, and online help, thus enabling the numerous options to be selected quickly and safely.

If BlueControl® is linked with an active device (online-mode), the most important process data and settings of the connected device can be monitored and changed, and the trend function also permits them to be recorded. The display is in real-time.

A completely risk-free procedure is provided by the detailed device and process simulation, primarily for testing control functions before commissioning, or for training purposes. This feature also permits the simulation of comprehensive functions and complex devices, without having to connect the device or process signals to the PC.

Versions

- Basic version: Functions and access to special device functions that are not available via front-panel operation.
- Expert version: provides additional special functions (see Table "Functions of BlueControl®-versions" page 7)

Functions

- Parametrizing: the primary task of BlueControl®
- Wizard for controller tuning
- Online-help
- Parameter-help (tool tips)
- Visibility of operation, extended operating level
- Upload / Download the data of an external device
- Simulation
- Online operation
- Export of a download list
- Linearisation export/import
- Print function
- Trend recording
- BluePort® maintenance manager
- Communication via Modbus, PROFIBUS or Ethernet

Prerequisites

Software

- BlueControl® runs under the operating systems Microsoft Windos 95, 98, ME, NT4, 2000 und XP

Hardware

- IBM-compatible PC, with Pentium processor
- at least 32MB working memory
- hard disk with at least 64MB free capacity
- VGA-graphics and a suitable monitor
- Floppy disk drive or CD-ROM drive
- Mouse or similar pointer device
- serial interface or USB adapter for connecting external devices

Order Code

Engineering-Tool	Version	
BlueControl®	Basic	multi-language
	Expert	multi-language
Order Example:	BlueControl® / Basic	

Example Parameter Setting with Online-Help

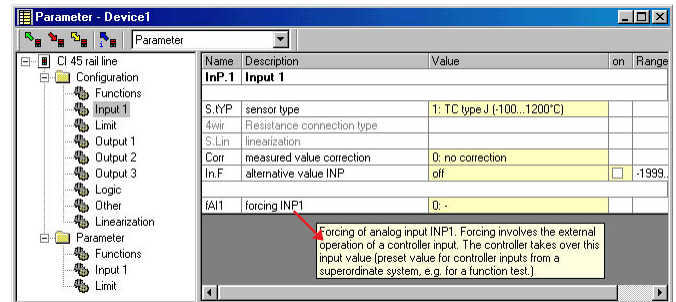

Example Simulation

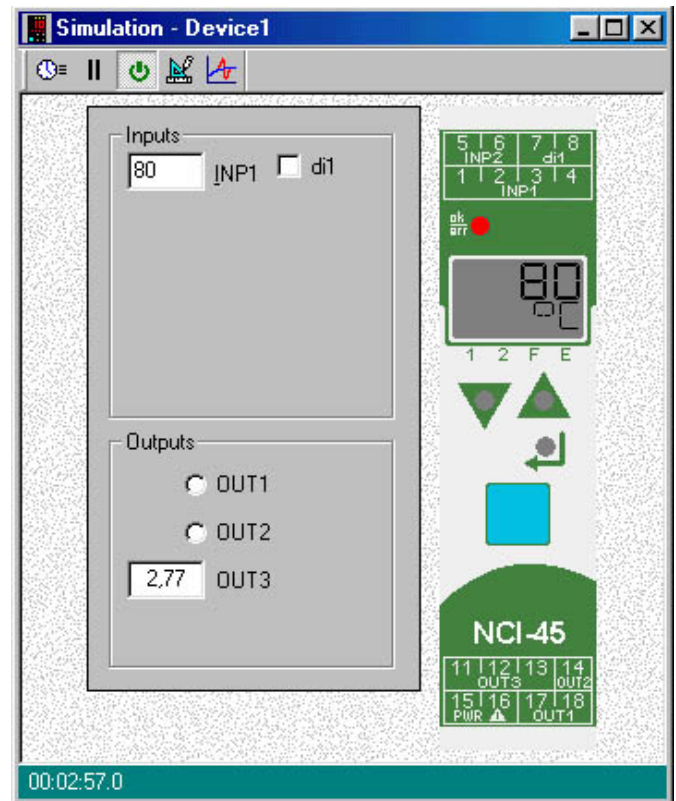

Example Data Up- / Download

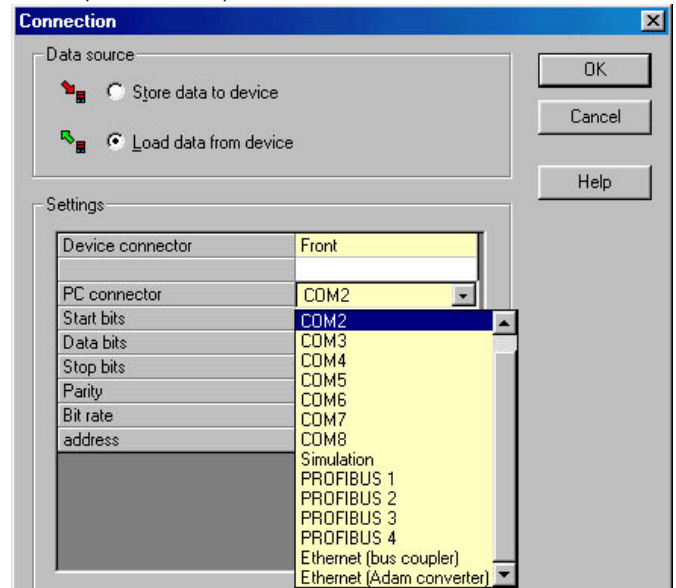

Order Code NCI-45

NCI - 45-1 (with 1 universal input, 1 digital input, display and BluePort®-interface)

Connection

1 connector set with screw terminals

Relays

4 90...260VAC, mA / V / logic + 2 relays
 5 18...30VAC / 18...31VDC, mA / V / logic + 2 relays

0 no option
 1 RS422 / 485 (only on request)

Options

0 no option
 2 options package 2 (additional universal input INP2;
 plus: O2 measurement, counter input, function tare, sample&hold, integrator)
 digital input as optocoupler, frequency input / output)

Configuration

000 standard configuration

Certification

U91 UL / cUL-certified (applied for)

Example:

NCI - 45-1 1 4 - 0 0 000 - U91

Order Code System Components

Fieldbus coupler PROFIBUS DP	RL40-112-00000-000
Fieldbus coupler PROFIBUS DP, UL / cUL-certificc (applied for)	RL40-112-00000-U00
Power supply module	RL40-119-00000-000
Power supply module, UL / cUL-certified (applied for)	RL40-119-00000-U00

Order Example: RL40-112-00000-000

Order Coded Documentation

Operating instructions NCI-45 german	9499-040-71718
Operating instructions NCI-45 english	9499-040-71711
Interface description for MODBUS rail line german	9499-040-72018
Interface description for MODBUS rail line english	9499-040-72011
Interface description for PROFIBUS-DP rail line german	9499-040-77118
Interface description for PROFIBUS-DP rail line english	9499-040-77111
Data sheet system components rail line german	9498-737-50933
Data sheet system components rail line english	9498-737-50913

Order Example: RL40-112-00000-000