

## Product Information ILM-4

## FOOD

# Inductive Conductivity Meter ILM-4



## Application/Specified Usage

- Inductive measurement of the specific conductivity of liquid media in the range of 0...1 000 mS/cm.
- Designed for hygienic applications in food-, beverage- and pharmaceutical industries.

## Application Examples

- Controlling of CIP processes (e. g. phase separation detergents/water)
- Concentration measurement (e. g. Alkali and acid concentration in remaking)
- Monitoring of product quality, quality control

## Hygienic Design/Process Connection

- Hygienic process connection with CLEANadapt
- Versions available with EHEDG approval
- Versions available to conform to 3-A Standard 74-
- All wetted materials are FDA-conform
- CRN: 0F18719.5C
- Sensor completely made of stainless steel, sensor tip of PEEK material
- Complete overview of process connections: see order code
- The Anderson-Negele CLEANadapt system offers a flow-optimized, hygienic and easily sterilizable installation solution for sensors.

## Features/Advantages

- CIP/SIP cleaning up to 150 °C (302 °F)/maximum 60 minutes
- Wear-free, inductive measurement
- In contrast to conductive measurement procedures, no problems with electrode deterioration or polarization.
- Accurate measurement through compensation of temperature influences.
- High reproducibility of  $\leq 0.2\%$  of measurement value.
- Analog outputs for conductivity and temperature are a standard feature.
- Analog outputs for conductivity, temperature or concentration are freely adjustable.
- Hybrid technology with digital and analog interface
- Short reponse time of 1.2 s for highest efficiency
- Installation in tube diameters from DN 40

## Options/Accessories

- Version with longer toroid housing for pipes  $\geq$  DN 65 or for installation into T-fitting
- Preassembled cable for M12 plug-in connector
- Display module Simple User Interface (SUI) and Large User Interface (LUI)
- Remote version with cable length up to 30 m
- Add-On Instructions are available at [www.anderson-negele.com/aoi](http://www.anderson-negele.com/aoi)

## Communication

 **IO-Link**  **4...20 mA**

## ILM-4 / L20 Compact Version



## ILM-4R / L20 Remote Version



## Large User Interface (LUI)



Specification		
<b>Process connection</b>	CLEANadapt Tri-Clamp Varivent	G1" 1½", 2", 2½", 3" DN 25 (type F), DN 40/50 (type N)
<b>Materials</b>	Connecting head Threaded connector Immersible body Plastic cap/sight glass	Stainless steel 1.4308 (AISI CF-8) Stainless steel 1.4305 (AISI 303) PEEK, FDA number 21 CFR 177.2415 Polycarbonate
<b>Temperature ranges</b>	Ambient Process CIP/SIP cleaning	-10...70 °C (14...158 °F) -10...130 °C (14...266 °F) Up to 150 °C (302 °F) max. 60 min
<b>Operating pressure</b>		Max. 16 bar (232 psi)
<b>Protection class</b>		IP 69 K
<b>Reproducibility</b>	of conductivity	≤ ±0,2 % of measured value
<b>Resolution/measurement range</b>	≤ 1 mS/cm ≤ 10 mS/cm ≤ 100 mS/cm ≤ 1000 mS/cm	0.001 mS/cm 0.01 mS/cm 0.1 mS/cm 1 mS/cm
<b>Accuracy</b>	Slope Offset	±1 % of measurement range (plus additional inaccuracy of calibration fluid) ±20 µS/cm
<b>Long-term stability</b>		±0.5 % of upper range limit
<b>Accuracy of temperature output</b>	≤ 100 °C (212 °F) 100...150 °C (212...302 °F)	Max. 0.5 °C (0.9 °F) Max. 1.0 °C (1.8 °F)
<b>Response time</b>	Conductivity Temperature (t <sub>90</sub> )	< 1.2 s < 20 s
<b>Electrical connection</b>	Cable gland Cable connection Power supply	2x M16 x 1.5 2x M12 connector 1.4301 (AISI 304) 18...36 V DC max. 190 mA
<b>Remote cable (ILM-4R only)</b>	PVC-cable	8 pin, twisted pair, unshielded, with M12 coupling/straight plug
<b>Communication</b>	Analog Digital	2x Analog output 4...20 mA, short circuit proof 1x Digital input (24 V DC) IO-Link
<b>LCD display</b>	Backlit display	5 lines
<b>Measuring principle</b>	Wear-free	Inductive

### Measuring Principle of the Inductive Conductivity Meter

An alternating current generates a magnetic field in the primary coil (sender) which induces a current in the circumfluent medium. The current flow in the medium generates another magnetic field in the secondary coil (receiver). The strength of the induced current in the secondary coil depends on the conductivity of the medium. The conductivity of the liquid medium is temperature dependent. To compensate the temperature error, an additional sensor (Pt1000) in the sensor tip is used for monitoring the temperature of the medium. The temperature coefficient (TC-value) of the liquid can be set up in the electronics of the ILM which is used for automatic compensation of the temperature error.

### Inductive Conductivity Measurement

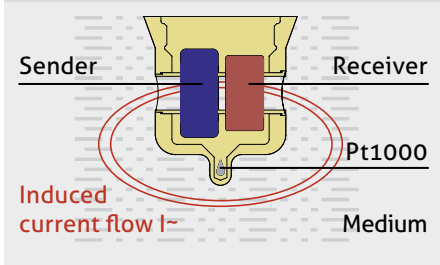

ILM-4 / G1" horizontal

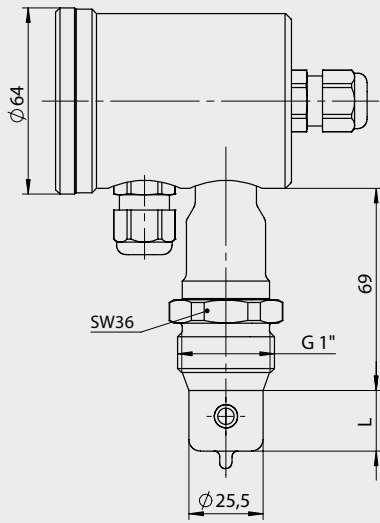

ILM-4 / G1" vertical

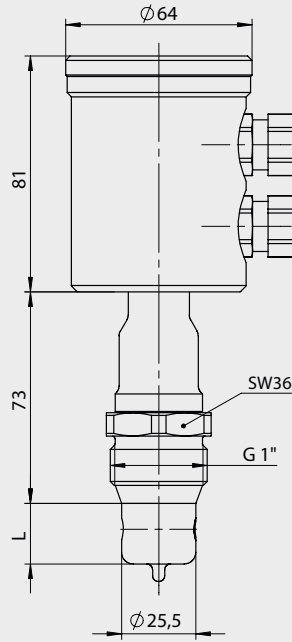

ILM-4 / Tri-Clamp vertical

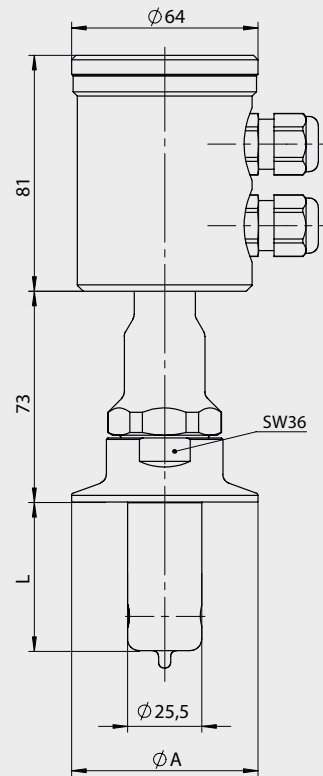

HUR / Head Unit Remote Version

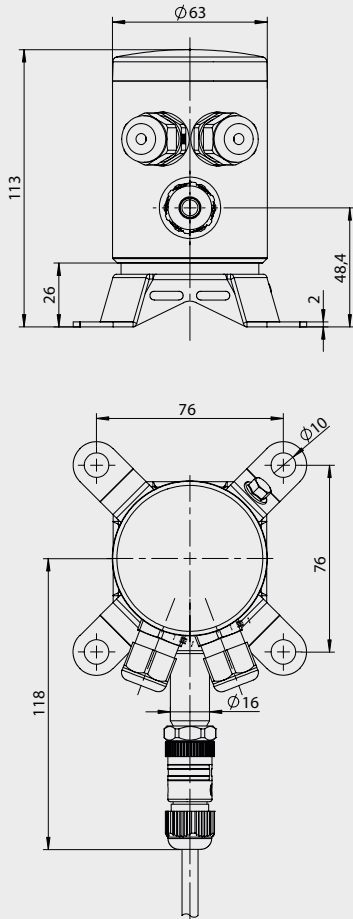

ILM-4S / G1" CLEANadapt

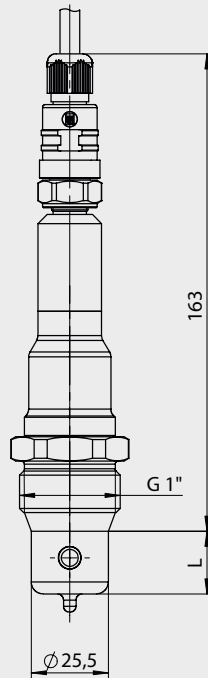

ILM-4S / Tri-Clamp

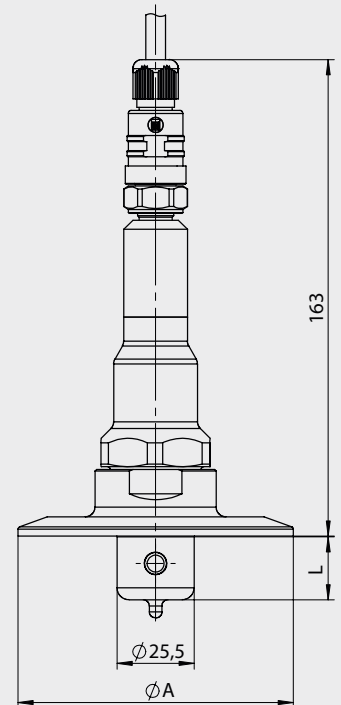

Submersion length

Type	L [mm / inch]
ILM-4 / L20	20.0 / 0.79
ILM-4 / L50	50.0 / 1.97

Tri-Clamp size

Type	Ø A [mm / inch]
TC1	50.5 / 1.99
TC2	64.0 / 2.52
T25	77.5 / 3.05
TC3	91.0 / 3.54

**Note**

This product information is not an operating manual. Please note the information on device safety, installation and operation in the product operating manual.

**Mechanical Connection / Installation**

- The sensor has to be installed in that way that the bobbin case is entirely washed around by media and no bubbles can occur. Installation in a rising pipe is recommended.
  - Special indications for hygienic installation (3-A, EHEDG) must be observed.
  - The inscription "FLOW" on the bottom side of the sensor has to show in flow direction of the medium.
  - Very heavy vibrations can cause measurement errors (e. g. installation very near a pump).
  - Use Negele CLEANadapt system for safe operation of measuring point!
  - Attention: The maximum tightening torque for mounting is 20 Nm!
  - Use a welding mandril for correct installation of CLEANadapt weld-in fittings.
- Please pay attention to the weld-in and installation details in the CLEANadapt product information.

**Note on 3-A Sanitary Standard 74-**

Information on installation according to 3-A standard is available on our website:  
[www.anderson-negele.com/3A74.pdf](http://www.anderson-negele.com/3A74.pdf)

Click on the PDF icon to download the document.

**Note on EHEDG Hygienic Standard Type EL Class I**

Information on installation according to EHEDG standard and indications for CLEANadapt adapters with leakage holes is available on our website:  
[www.anderson-negele.com/EHEDG.pdf](http://www.anderson-negele.com/EHEDG.pdf)

Click on the PDF icon to download the document.

**Note on IO-Link**

Information on parameters and events are available on our website:

[www.anderson-negele.com/iodd](http://www.anderson-negele.com/iodd)

Click on the IO-Link icon to open the website.

**Information**

The components ILM-4S / sensor and HUR / Head Unit Remote can be purchased as spare parts separately. The valid configuration can be seen on the product labels.

Application / Function	Signal module	I42	I62	I63
IO-Link communication X3		✓	✓	✓
2x analog output X45 and X67 for conductivity and temperature		—	✓	✓
1x digital input X3 for external range switching		—	—	✓

Table electrical connection

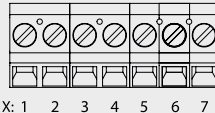
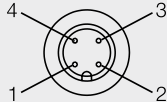
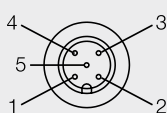
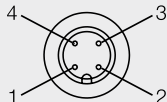
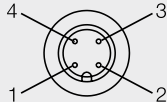
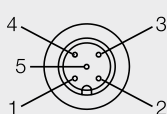
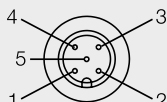
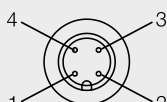
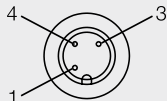
Type	Connection	Pin assignment				
P (1x PG) D (2x PG)	 X: 1 2 3 4 5 6 7	Clamps	1: Power supply +24 V DC 2: Power supply - 3: Digital input X3 4: Analog output X45 + 5: Analog output X45 - 6: Analog output X67 + 7: Analog output X67 -	✓	✓	✓
A (2x M12)		4 pin	1: Analog output X45 - 2: Analog output X45 + 3: Power supply +24 V DC 4: Power supply -	—	✓	✓
		5 pin	1: Analog output X67+ 2: Not assigned 3: Not assigned 4: Analog output X67 - 5: Digital input X3			
M (1x M12)		4 pin	1: Power supply +24 V DC 2: Analog output X45 + 3: Analog output X45 - 4: Power supply -	✓	—	—
N (2x M12)		4 pin	1: Analog output X45 + 2: Analog output X67 + 3: Analog output X67 - 4: Analog output X45 -	—	✓	✓
		5 pin	1: Power supply +24 V DC 2: Not assigned 3: Not assigned 4: Power supply - 5: Digital input X3			
C (1x M12) IO-Link		5 pin	1: Power supply +24 V DC 2: Analog output X45 - 3: Power supply - 4: IO-Link 5: Analog output X45 +	✓	—	—
R (2x M12) IO-Link		4 pin	1: Analog output X45 + 2: Analog output X67 + 3: Analog output X67 - 4: Analog output X45 -	—	✓	✓
		3 pin	1: Power supply +24 V DC 3: Power supply - 4: IO-Link / Digital input X3			

## Order code

**ILM-4** Inductive conductivity sensor  
**ILM-4R** Inductive conductivity sensor - remote version

## Submersion length of toroid

**L20** 20 mm  
**L50** 50 mm

## Process connection

(<sup>Ⓐ</sup>: 3-A conform, <sup>Ⓔ</sup>: EHEDG approval (only with CLEANadapt adapter with leakage hole))

<b>S01</b>	CLEANadapt G1" <sup>Ⓐ</sup> <sup>Ⓔ</sup>	<b>TC1</b>	Tri-Clamp 1½" <sup>Ⓐ</sup>
<b>V25</b>	Varivent type F, DN 25 <sup>Ⓐ</sup>	<b>TC2</b>	Tri-Clamp 2" <sup>Ⓐ</sup>
<b>V40</b>	Varivent type N, DN 40/50 <sup>Ⓐ</sup>	<b>T25</b>	Tri-Clamp 2½" <sup>Ⓐ</sup>
		<b>TC3</b>	Tri-Clamp 3" <sup>Ⓐ</sup>

## Head orientation (not selectable for ILM-4R)

**H** Horizontal head orientation  
**V** Vertical head orientation

## Signal module

**I42** IO-Link and 1x 4...20 mA conductivity  
**I62** IO-Link and 2x 4...20 mA conductivity/temperature selectable  
**I63** IO-Link and 2x 4...20 mA conductivity/temperature selectable, external range switching

## Electrical connection

**P** Cable gland M16x1.5  
**D** 2x cable gland M16x1.5  
**M** 1x M12 connector, 4 pin output/power supply  
**N** 2x M12 connector, 4 pin output, 5 pin input/power supply  
**A** 2x M12 connector, 4 pin output/power supply, 5 pin output/input  
**C** 1x M12 connector, 5 pin analog output and IO-Link  
**R** 2x M12 connector, 4 pin analog and switching output, 3 pin IO-Link and input

## Interface/Display

**X** Without  
**S** Simple User Interface with small display (not for ILM-4R)  
**L** Large User Interface with big display

## Enclosure

**X** Plastic cap without sight glass  
**P** Plastic cap with sight glass  
**M** Stainless steel cap without sight glass  
**W** Stainless steel cap with sight glass

## Configuration

**X** Default factory settings  
**S** Special customer settings

## Remote transmitter interconnect cable

(PVC, 8 pin, M12 plug)

**05P** Length 5 m, plastic coupling  
**10P** Length 10 m, plastic coupling  
**20P** Length 20 m, plastic coupling  
**XXP** Special length, plastic coupling, 30 m max, steps of 1 m  
**05S** Length 5 m, stainless steel coupling  
**10S** Length 10 m, stainless steel coupling  
**20S** Length 20 m, stainless steel coupling  
**XXS** Special length, stainless steel coupling, 30 m max, steps of 1 m  
**000** Without remote cable

**ILM-4 / L20 / S01 / V / I63 / D / S / P / X**

**ILM-4R / L20 / S01 / I63 / D / L / P / X / 05P**