

Process adapters and fittings

FOOD

Hygienic installation systems for pipes and tanks in food applications

CLEANadapt

Elastomer-free, hygienic universal adaptation

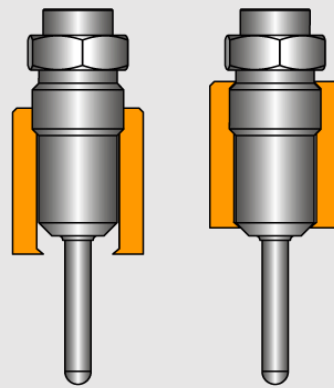

CLEANadapt KSF

Temperature adaptation with adjustable depth clamping technology

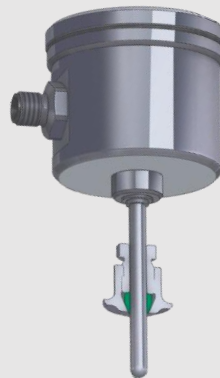

FLEXadapt ESF

Temperature measurement without media contact

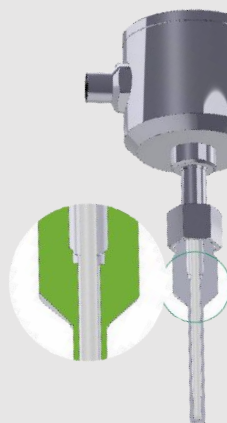

Process installation system for all measuring technologies in pipes and tanks Hygienic elastomer-free adaptation

"Hygienic by Design" – this means sensor integration in all food applications in a simple and safe manner. For that purpose, the universal CLEANadapt installation system offers a **variety of adapters and fitting** components for almost all common sensor types.

In the CLEANadapt system, which has been specially developed for food applications, **flow-optimised pipe Tees, weld-in sleeves or adapters for existing process connections** are easily integrated into tanks or pipes and the sensors are screwed in.

- **Hygienic sealing principle:** A conical surface on the sensor connection piece is pressed against the sealing edge of the adapter through defined screw fixation. This results in a **simple, safe and permanent, maintenance-free and hygienic adaptation without dead legs, elastomers, seals or Teflon tape**
- **Three thread sizes, universal application:** With the dimensions **M12, G½" and G1"**, sensors for temperature, point level, continuous level, flow, pressure, conductivity and turbidity can be integrated easily
- **Simple, flexible installation:** **Weld-in sleeves** for a wide range of installation situations in tanks and pipes. **Pipe Tees** for safe and hygienic welding (orbital method) in pipes from DN15 to DN100. **Process adapters** for direct mounting on existing process connections such as Tri-Clamp, Varivent and many more.
- **Original components ensure safety:** Only Original welding sockets are always provided with the Anderson-Negele logo and guarantee the best possible system tightness
- **Cost-saving stock-keeping:** With CLEANadapt, each sensor variant can be flexibly integrated into any installation situation, thus minimizing spare parts inventory and planning requirements

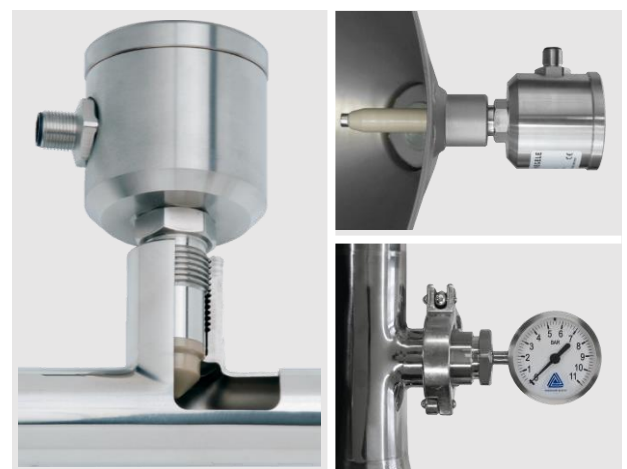
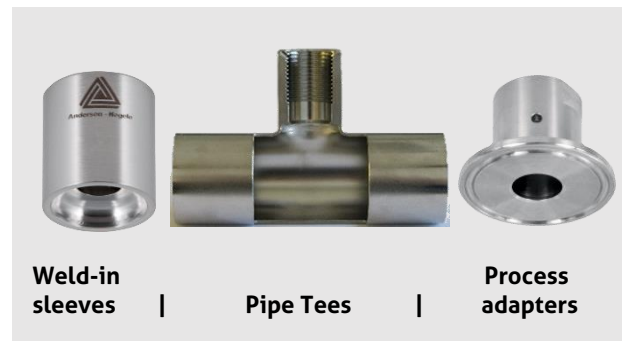

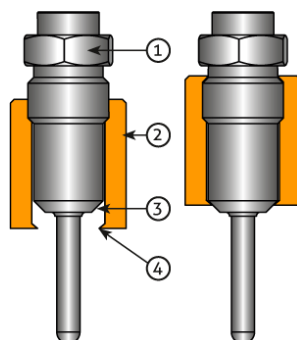

Schematic of the CLEANadapt sealing principle

1. Sensor stem
2. Weld-in sleeve / Tee / adapter
3. Cone on the sensor (PEEK or metal)
4. Sealing edge (metal)





Hygienic process adaptation
for almost every sensor and
application





EHG Fitting system (Details see product information)

	Type	Thread	Pipe widths DN	Material: Stainless steel 1.4404 option: 2.2 certificate acc. to DIN EN 10204 on request: 1.4435 with 3.1 certificate For further accessories such as seals, press rings, clamp rings, dummy flanges, welding mandrels etc. see product information
	EHG-DIN2-... / M12	M12	DN 15 20 25 40 50 65 80	
	EHG-DIN2-... / 1/2"	G1/2"	DN 25 40 50 65 80 100	
	EHG-DIN2-... / 1"	G1"	DN 40 50 65 80 100	

Weld-in sleeves EM... (Details see product information)

	Type	Thread	Application		Type	Thread	Application
	EMZ - Cylindrical sleeve	G1/2" G1"	For vessels		EMS - Cylindrical sleeve with weld-in ring	M12 G1/2" G1"	For installation on pulled-out pipes
	EMZ - Cylindrical sleeve with leakage hole	G1/2" G1"	For vessels, with leakage detection		EMS - Cylindrical sleeve with weld-in ring and leakage hole	M12 G1/2" G1"	For installation on pulled-out pipes, with leakage detection
	EMK - Weld-in collar sleeve	M12 G1/2"	For thick-walled vessels		KEM - Weld-in ball	M12	For sloped installation

Adapters AM... for existing process connections (Details see product information)

	Type	Thread	For pipe widths
      	AMK for milk pipe DIN 11851	M12 G1/2" G1"	DN 10 15 25 40 50 DN 20 25 32 40 50 65 80 100 DN 25 32 40 50 65 80 100
	AMC for Tri-Clamp	M12 G1/2" G1"	DN 10 15 25 40 50 65 80 100 1" 1 1/2" 2" 2 1/2" 3" DN 10 15 20 25 32 40 50 65 80 1" 1 1/2" 2" 2 1/2" 3" DN 25 32 40 50 65 80 100 1" 1 1/2" 2" 2 1/2" 3"
	AMC for Tri-Clamp, with leakage hole	M12 G1/2" G1"	DN 10 15 25 40 50 65 80 100 1" 1 1/2" 2" 2 1/2" 3" DN 25 32 40 50 65 80 100 1" 1 1/2" 2" 2 1/2" 3"
	AMV for Varivent Inline	M12 G1/2" G1"	DN 10 25 40 DN 10 25 40 DN 25 40
	AMA for APV- Inline	M12 G1/2" G1"	From DN 40 From DN 40 From DN 40
	AMK for SMS	M12 G1/2"	DN 40 50 1 1/2" 2" DN 20 40 50 1 1/2" 2"
	AMB for BioControl	M12 G1/2" G1"	G 25 50 G 50 65 G 50 65

Adapters AMG for existing thread connections (Details see product information)

	For sensors with thread	On existing thread connection
	M12 G1/2" G1"	G1/2" G3/4" G1" G3/4" G1/2" G1 3/4" G2"

Simplified clamps for adjustable depth or non-contact temperature measurement „Clamp & Play“ – Easy & sealed adaptation

With the CLEANadapt KSF installation system, a **temperature sensor without thread** is fastened either in a weld-in sleeve or in a weld-in thermowell. By means of a compression fitting this is easy to realize, without dead space. By tightening the clamp screw, a cone-shaped **PEEK sealing ring without elastomers** provides a reliable seal up to an **operating pressure of 10 bar**.

- **Thermowell option:** a ball socket with integrated thermowell is **permanently welded into tanks or pipes**. The slim probe tip of the sensor is inserted into this thermowell and is therefore **not in contact with the medium**. The sensor can thus be removed for **recalibration or replacement** at any time without opening the process, i.e. **without downtime of the plant**.

- **Welding sleeve option:** A collar sleeve or ball sleeve is **welded into tanks or pipes**. The probe tip of the sensor can now be fastened in this sleeve **with adjustable depth, in contact with the medium**, by means of a **compression fitting**. This makes it possible to change the immersion depth at any time or to use **one probe length for different nominal pipe diameters**.

Available Temperature sensors

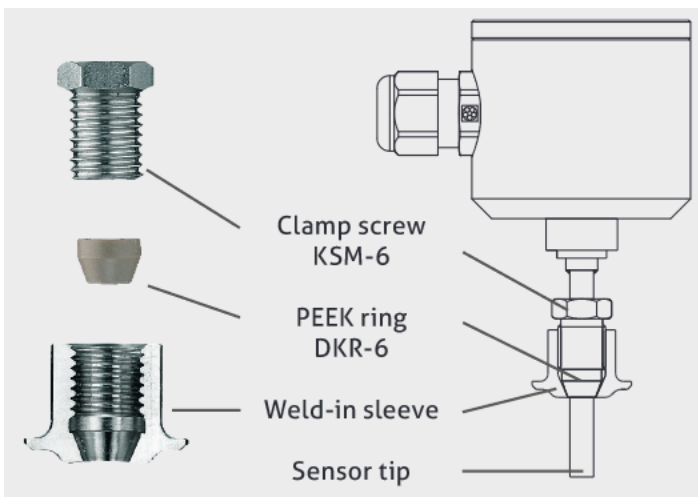

- TSM (N01) / TSB (N01) / TFP-06
- Accuracy class: A | AA (1/3B) | AAA (1/10B)
- Options: 2x Pt100 | LCD display | transmitter

Schematic of the CLEANadapt KSF sealing principle





The easy clamp connection for every application, in all pipes and tanks

TFP Temperature sensor (Details see respective product information)

	Type	Head Ø	Pt	Transmitter available	Electrical connection	Probe length in mm (Special lengths on request)
	TSB	57 mm	Pt100 Pt1000	✓	M12 plug PG cable gland	0...2000
	TSB (Display)	63 mm	Pt100 Pt1000	✓	M12 plug PG cable gland	0...2000
	TSM	18,5 mm	Pt100 Pt1000	✓	M12 plug	0...2000
	TFP-06	6 mm (no head)	✓	-	PVC Fixed cable	50...250
	TFP-06-IP68	6 mm (no head)	✓	-	PTFE Fixed cable Protection class IP68	50...250

Thermowells / Weld-in sleeves (Details see product information)

Material: Stainless steel 1.4404 (316L), Option: 1.4435 with 3.1 certificate

	Type	Application	Sleeve length	For probe length
	ESH-KM12	Thermowell in ball shape for sloped weld fixation in pipes, pipe knees and tanks For probe diameter Ø6mm	85 mm 150 mm 230 mm 400 mm	From 100 mm From 165 mm From 245 mm From 415 mm
	ESH-KM12-6	Thermowell in ball shape for sloped weld fixation in pipes, pipe knees and tanks For probe diameter Ø4mm	85 mm 150 mm 230 mm 400 mm	From 100 mm From 165 mm From 245 mm From 415 mm
	EMK-25/76	Weld-in collar sleeve for pipes and tanks	17 mm	Adjustable depth
	KEV-25/76	Weld-in ball sleeve for sloped weld fixation in pipes, pipe knees and tanks	17 mm	Adjustable depth

No process interruption due to sensor removal during recalibration or replacement
Temperature control without media contact

With the FLEXadapt ESF installation system, a thermowell is **permanently installed** in the process. The slim tip of the sensor is inserted into this thermowell and maintained in contact by a spring. It is therefore **not in direct contact** with the medium.

The sensor can be removed at any time for **recalibration or replacement**, without opening or stopping the process, and consequently **without downtimes of the plant**.

- **Tailored to requirements:** Special design for food applications
- **Variable:** Installation **in tanks** using welding sockets, welding sleeves or adapters. Installation **in pipes** using tees or elbows with integrated thermowells
- **Ideal for Retrofitting:** Screw-in socket for easy conversion of existing G1/2" process connections
- **One for all:** One sensor type with the same probe length can be used for differing pipe widths, thus **minimizing spare parts inventory** and planning requirements
- **Reliable:** Spring-mounted tip for perfect contact
- **Maximum hygiene:** No product contact = **No risk of contamination** by previous products, foreign bodies and germs via the sensor
- Easy to clean in CIP/SIP: **design without dead-legs**
- **Precise:** measuring accuracy $< \pm 0,25 \text{ }^\circ\text{C}$

Available temperature sensors

- TSB / TSM
- **Accuracy class:** A | AA (1/3B) | AAA (1/10B)
- **Options:** 2x Pt100 | LCD display | transmitter

Available installation systems for pipes and vessels

- Screw-in thermowells
- Weld-in thermowells
- Ball-shape thermowells



Additional components from the PHARMadapt ESP range:

- **Extended sleeves** for insulated / double-walled vessels
- **Adapters** for diverse process connections (Tri-Clamp, Varivent...)
- **Fittings with pipe sections** (orbital welding, to reduce time and quality problems compared to sleeve welding):
 - Tees DN8...DN100
 - Elbows DN10...25 | DN 1/2" ...1"

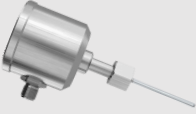

Our top installation solution for every application, in all pipes and tanks

TSB / TSM Temperature sensors (Details see respective product information)







	Type	Head Ø	Pt	Transmitter available	Electrical connection	Probe length in mm
	TSB	57 mm	Pt100 Pt1000	✓	M12 plug PG cable gland	37 59 83 97 / 160
	TSB (Display)	63 mm	Pt100 Pt1000	✓	M12 plug PG cable gland	37 59 83 97 / 160
	TSM	18,5 mm	Pt100 Pt1000	✓	M12 plug	37 59 83 97 / 160

FLEXadapt ESF / PHARMadapt ESP Fitting systems (Details see respective product information)

Material / Surface:

Type ESF: 1.4404 (316L), Ra ≤ 0.8 µm

Type ESP: 1.4435 (316L) with 3.1 certificate, Ra ≤ 0.8 µm electropolished, option: Ra ≤ 0.6 µm / 0.4 µm

	Type	Application	For probe length	Installation length
	ESF-EH	Thermowell for pipes and tanks, weld or clamp fixation	83 mm 160 mm	Immersion length: 50 127 mm
	ESF-KM	Thermowell in ball-shape, for sloped weld installation in pipes, elbows or tanks	83 mm 160 mm	Immersion length: 50 127 mm
	ESF-G1/2"	Threaded thermowell for existing G1/2" CLEANadapt measure point	83 mm 97 mm 160 mm	Immersion length: 27 41 104 mm
	ESP-E	Weld-in thermowell for pipes and tanks	83 mm 160 mm	
	ESP-Adapter	Adapter with integrated thermowell for Tri-Clamp, Bio-Control, Varivent, Fermenter	See product information	
	ESP-G	Pipe Tee with integrated thermowell DIN 2: DN10...DN100 ISO: DN8...DN80 ASME: ½" ...4"	37 mm 83 mm With ESP-VL: 83 mm 160 mm	Pipe 70...310 mm
	ESP-W	Pipe Elbow with integrated thermowell DIN 2: DN10...DN25 ISO: DN8...DN20 ASME: ½" ...1"	37 mm With ESP-VL 46: 83 mm With ESP-VL 123: 160 mm	Pipe 35...55 mm resp. 62...88 mm
	ESP-VL	Extension 46 or 123 mm, for ESP-G Tees or ESP-W elbows	Extension from 37 mm to 83 mm 160 mm	

Process adapters and fittings

FOOD



North America

Anderson Instrument Company Inc.
Fultonville, NY 12072
USA

Tel. +1 518-922-5315
Fax +1 518-922-8997
info@anderson-negele.com

Europe / EMEA

Negele Messtechnik GmbH
Raiffeisenweg 7, 87743 Egg an der Guenz
GERMANY

Tel. +49 8333-9204-0
Fax +49 8333-9204-49
sales@anderson-negele.com

India

Anderson-Negele India
Kurla (West), Mumbai – 400 070
INDIA

info.india@anderson-negele.com

China

Anderson-Negele China
518 Fuquan North Road, Shanghai,
200335
P.R. CHINA

Tel. +86 400 666 1802-7
china.sales@anderson-negele.com

Latin America

SPTech
Tamboré - Barueri - São Paulo
BRASIL

Tel. +55 11 3616-0150
atendimento@sptech.com